



ej

ejco.com

ALUMATIC®
Recessed & Solid Top



ALUMATIC® LITE

Recessed FACTA Class AA

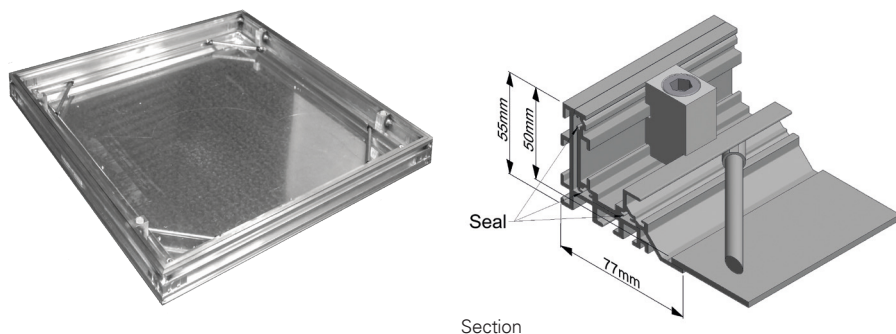

Triple sealed recessed access cover suitable for up to 18 mm tile/floor finish infill. Covers are designed to be infilled with C40 concrete to achieve full loading. The Alumatic® Lite features M10/M12 Lock & Lift devices. The Lite also boasts triple sealing facilities comprising of a primary dirt seal to protect against the ingress of dirt, alongside secondary and tertiary EPE inner seals to prevent the ingress/egress of gas, air and water. All products are manufactured under an ISO 9001 Quality system. This product is manufactured from Aluminium alloy 6063 and 6082 for low corrosion and superior finish.

Duct runs and beamed multiple configurations are available. Single units are gas, air and watertight at normal atmospheric pressure. Twin units feature a removable support beam and are watertight at normal atmospheric pressure.

Features:

- Lock & Lift as standard
- Stainless steel locking bolts
- Triple sealed
- High resistance to corrosion
- Accommodates up to 18 mm infill

Options:

- Aluminium Edging
- Brass Edging

Standard Sizes

Code	Clear Opening (mm)	O/all Frame (mm)	Frame Depth (mm)	No of Covers
AL23030	300 x 300	410 x 410	55	Single
AL24545	450 x 450	560 x 560	55	Single
AL26045	600 x 450	710 x 560	55	Single
AL26060	600 x 600	710 x 710	55	Single
AL27560	750 x 600	860 x 710	55	Single
AL27575	750 x 750	860 x 860	55	Single
AL29075	900 x 750	1010 x 860	55	Single
AL29090	900 x 900	1010 x 1010	55	Twin
AL210060	1000 x 600	1010 x 710	55	Twin
AL210075	1000 x 750	1010 x 860	55	Twin
AL212060	1200 x 600	1310 x 710	55	Twin

Non-standard sizes available

ALUMATIC® LITE

Vinyl

FACTA Class A



Triple sealed recessed access cover suitable for up to 3 mm vinyl finish infill. Covers are infilled with aluminium planking to leave a 3 mm recess. The Alumatic® Lite features M10/M12 Lock & Lift devices. The Lite also boasts triple sealing facilities comprising of a primary dirt seal to protect against the ingress of dirt, alongside secondary and tertiary EPE inner seals to prevent the ingress/egress of gas, air and water. All products are manufactured under an ISO 9001 Quality system. This product is manufactured from Aluminium alloy 6063 and 6082 for low corrosion and superior finish.

Single units are gas, air and watertight at normal atmospheric pressure. Twin units feature a removable support beam and are watertight at normal atmospheric pressure.

Features:

- Lock & Lift as standard
- Stainless steel locking bolts
- Triple sealed
- High resistance to corrosion
- Accommodates up to 18 mm infill

Options:

- Aluminium Edging
- Brass Edging

Standard Sizes

Code	Clear Opening (mm)	O/all Frame (mm)	Frame Depth (mm)	No of Covers
ALV3030	300 x 300	410 x 410	55	Single
ALV4545	450 x 450	560 x 560	55	Single
ALV6045	600 x 450	710 x 560	55	Single
ALV6060	600 x 600	710 x 710	55	Single
ALV7560	750 x 600	860 x 710	55	Single
ALV7575	750 x 750	860 x 860	55	Single
ALV9075	900 x 750	1010 x 860	55	Single
ALV9090	900 x 900	1010 x 1010	55	Twin

[Non-standard sizes available](#)

ALUMATIC®

Single Recessed FACTA Class B

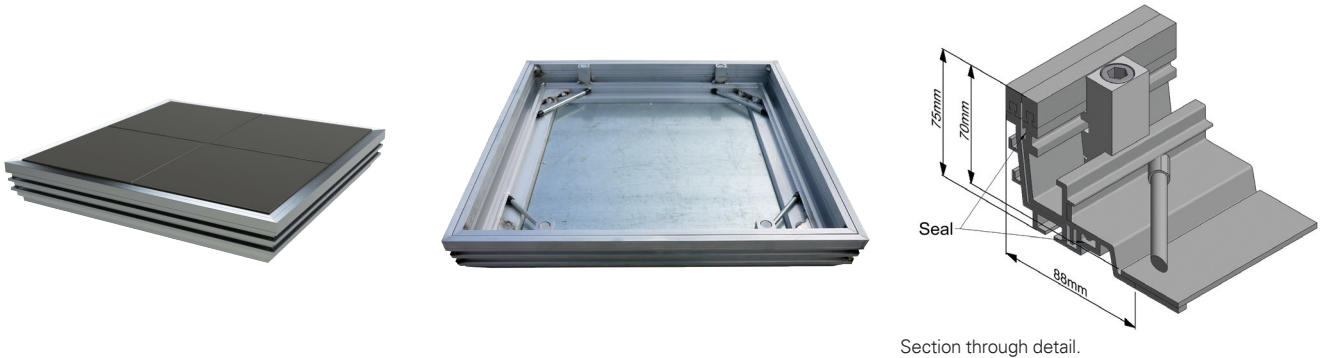

Triple sealed recessed access cover suitable for a high-quality floor finish up to a depth of 50 mm of tile, carpet, blocks or terrazzo infill. Aluminium or brass edging strips are 8 mm deep, which allows edges to be ground and polished in-situ up to 6 mm.

Covers are designed to be infilled with C40 concrete to achieve full loading. The Alumatic® features M10/M12 Lock & Lift devices. The Alumatic® also boasts triple sealing facilities comprising of a primary and a secondary seal to protect against the ingress of dirt and fluids, alongside an inner grease seal to prevent the ingress/ egress of gas, air and water. All products are manufactured under an ISO 9001 Quality system. This product is manufactured from Aluminium alloy 6063 and 6082 for low corrosion and superior finish.

Single units are gas, air and watertight at normal atmospheric pressure.

The ALUMATIC® range has a number of unique features designed to improve appearance and performance:

Features:

- 8 mm deep architectural edgings
- Lock & Lift as standard
- Stainless steel locking bolts
- Triple sealed (including grease seal)
- High resistance to corrosion
- Accommodates up to 50 mm infill

Options:

- Aluminium Edging
- Brass Edging
- 2 Hours Fire Integrity Rated

Standard Sizes

Code	Clear Opening (mm)	O/all Frame (mm)	Frame Depth (mm)	No of Covers
AL43030	300 x 300	428 x 428	76	Single
AL44545	450 x 450	578 x 578	76	Single
AL46045	600 x 450	728 x 578	76	Single
AL46060	600 x 600	728 x 728	76	Single
AL47560	750 x 600	878 x 728	76	Single
AL47575	750 x 750	878 x 878	76	Single
AL49075	900 x 750	1028 x 878	76	Single

[Non-standard sizes available](#)

ALUMATIC®
Twin Recessed
FACTA Class B



Triple sealed twin recessed access cover suitable for a depth of up to 50 mm of tile, carpet, blocks or terrazzo infill. Aluminium or brass edging strips are 8 mm deep, which allows edges to be ground and polished in-situ up to 6 mm.

Covers are designed to be infilled with C40 concrete to achieve full loading. The Alumatic® features M10/M12 Lock & Lift devices. The Alumatic® also boasts triple sealing facilities comprising of a primary and a secondary seal to protect against the ingress of dirt and fluids, alongside an inner grease seal to prevent the ingress/ egress of gas, air and water. All products are manufactured under an ISO 9001 Quality system. This product is manufactured from Aluminium alloy 6063 and 6082 for low corrosion and superior finish.

Twin units feature a removable support beam and are watertight at normal atmospheric pressure.

The ALUMATIC® range has a number of unique features designed to improve appearance and performance:

Features:

- 8 mm deep architectural edgings
- Lock & Lift as standard
- Stainless steel locking bolts
- Triple sealed (including grease seal)
- High resistance to corrosion
- Accommodates up to 50 mm infill

Options:

- Aluminium Edging
- Brass Edging
- 2 Hours Fire Integrity Rated

Standard Sizes

Code	Clear Opening (mm)	O/all Frame (mm)	Frame Depth (mm)	No of Covers
AL49090	900 x 900	1028 x 1028	76	Twin
AL410060	1000 x 600	1028 x 728	76	Twin
AL410075	1000 x 750	1028 x 878	76	Twin
AL412060	1200 x 600	1328 x 728	76	Twin

[Non-standard sizes available](#)

ALUMATIC®

Duct Recessed FACTA Class B

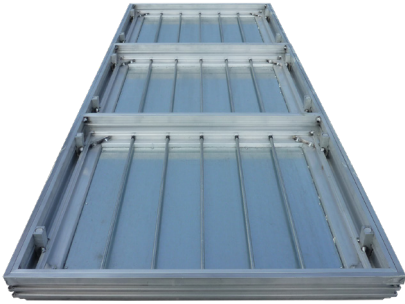

Triple sealed recessed access cover suitable for up to a depth of 50 mm of tile, carpet, blocks or terrazzo infill. Aluminium or brass edging strips are 8 mm deep, which allows edges to be ground and polished in-situ up to 6 mm. Covers are designed to be infilled with C40 concrete to achieve full loading. The Alumatic® features M10/M12 Lock & Lift devices. The Alumatic® also boasts triple sealing facilities comprising of a primary and a secondary seal to protect against the ingress of dirt and fluids, alongside an inner grease seal to prevent the ingress/egress of gas, air and water. All products are manufactured under an ISO 9001 Quality system. This product is manufactured from Aluminium alloy 6063 and 6082 for low corrosion and superior finish.

Duct units feature a removable support beam and are watertight at normal atmospheric pressure.

The ALUMATIC® range has a number of unique features designed to improve appearance and performance:

Features:

- 8 mm deep architectural edgings
- Lock & Lift as standard
- Stainless steel locking bolts
- Triple sealed (including grease seal)
- High resistance to corrosion
- Accommodates up to 50 mm infill

Options:

- Aluminium Edging
- Brass Edging
- 2 Hours Fire Integrity Rated

Sizes:

Units are manufactured to suit customer chamber sizes.

ALUMATIC®
Multiple Recessed
FACTA Class B

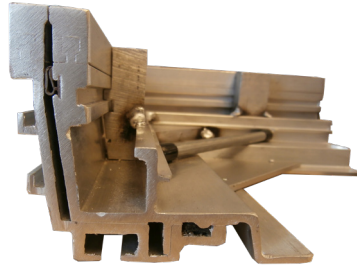
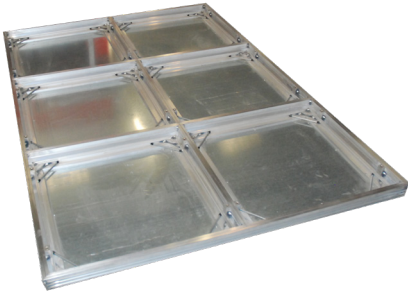

Triple sealed multiple recessed access cover suitable for up to 38 mm tile/floor finish infill. Aluminium or brass edging strips are 8 mm deep, which allows edges to be ground and polished in-situ up to 6 mm. Covers are designed to be infilled with C40 concrete to achieve full loading. The Alumatic® features M10/M12 Lock & Lift devices. The Alumatic® also boasts triple sealing facilities comprising of a primary and a secondary seal to protect against the ingress of dirt and fluids, alongside an inner grease seal to prevent the ingress/egress of gas, air and water. All products are manufactured under an ISO 9001 Quality system. This product is manufactured from Aluminium alloy 6063 and 6082 for low corrosion and superior finish.

Multiple units feature removable support beams and are watertight at normal atmospheric pressure.

The ALUMATIC® range has a number of unique features designed to improve appearance and performance:

Features:

- 8 mm deep architectural edgings
- Lock & Lift as standard
- Stainless steel locking bolts
- Triple sealed (including grease seal)
- High resistance to corrosion
- Accommodates up to 50 mm infill

Options:

- Aluminium Edging
- Brass Edging
- 2 Hours Fire Integrity Rated

Sizes:

Units are manufactured to suit customer chamber sizes.

